

# BALL VALVES INTEC

K220, DN125 - DN200, PN16/40

with floating ball, soft seated,  
single side spring loaded seat ring

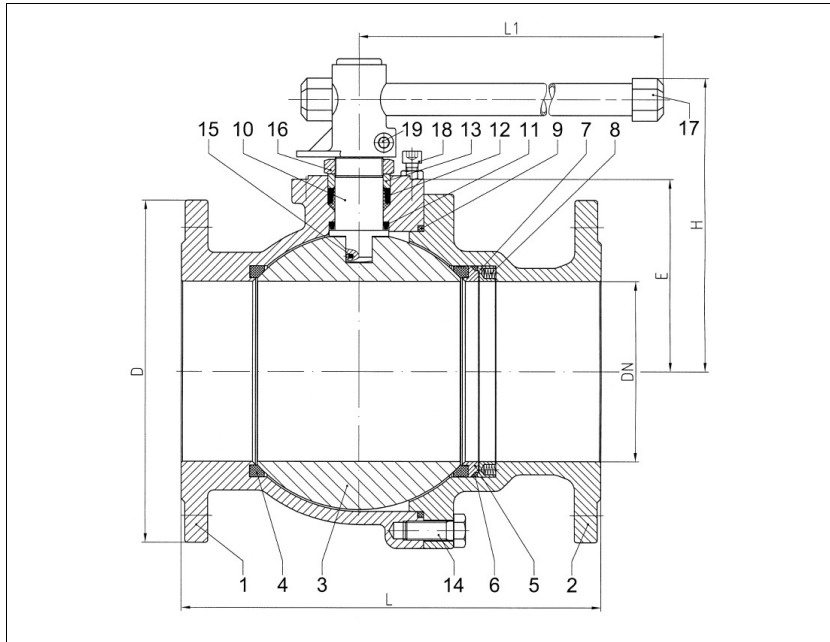

**Flanged ball valve**  
**full bore**  
**face to face acc. to EN 558, GR. 27**  
**flanges acc. to EN 1092**

**Specification:**

Two-piece ball valve with flanges acc. to EN 1092, face to face dimensions acc. to EN 558, GR.27, full bore, blow-out-proof stem, body material stainless steel (1.4408) or carbon steel (1.0619), antistatic device, free of non ferrous metals, seat full chambered, single side spring loaded seat ring, stem packing Graphite/KFGN/KFAM cone ring system dynamic loaded adjustable, top flange DIN EN ISO 5211, approved by PED, certified acc. to GERMAN clean air act VDI 2440, Fire-Safe acc. to DIN EN ISO 10497, with lever.

Marking: INTEC K220

No.	Part	Material	Material
<b>Standard design</b>			
1	body	1.0619	1.4408
2	cap	1.0619	1.4408
3	ball	1.4408	
4	seat	KFGN/KFM	
5	seat bearing ring	1.4571/1.4404	
6	seat seal	KF	
7	follower ring	1.4571/1.4404	
8	spiral spring	1.4401	
9	body seal	KF	
10	stem	1.4462	
11	below seal	KFGN/Graphite	
12	upper seal	KFAM/Graphite	
13	bearing	PEEK	
14	hex. screw	A4-70	
15	antistatic element	1.4401/1.4571/1.4404	
16	hex. nut self-locking	A2/1.4301	
17	lever	1.4408/1.4308/steel zincplated	
18	stopper	A2	
19	allen screw	A2-70	
<b>Fire-Safe design</b>			
6	seat seal	Graphite	
8	spiral spring	Inconel X750	
9	combined body seal	KF-Graphite	
13	Fire-Safe seal	Graphite	
	ring	1.4571/1.4404	
	thrust washer	PEEK	

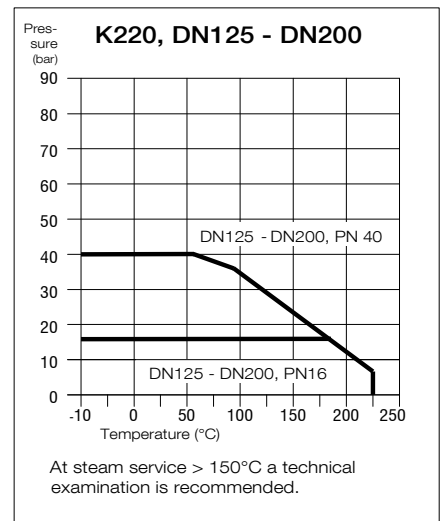

**Ordering example:**  
**INTEC K220, DN150, PN40, GR.27,**  
**1.4408, Fire-Safe**

**Dimensions**

DN mm	PN	dimensions (mm)					top flange ISO	torque Nm**	weight kg
		H	L1	L	D	E			
125	16	263	700	325	250	164	F12	260	56
125	40	263	700	325	270	164	F12	260***	58
150	16	265	700	350	285	160	F12	286	80
150	40	265	700	350	300	181	F12	286***	85
200	16	340	1000	400	340	225	F14	442	152
200	40	340	1000	400	375	225	F14	442***	160

\*\* Necessary torque measured with treated water at Δ P = 16 bar and room temperature.

\*\*\* PN40 gearbox recommended.

Subject to technical modification. 08/2018